

RCA 101

Car Alarm &
Radio Remote Control
with turn signal triggering

Mounting Instructions

Fiat



■ Warranty

No responsibility is taken for the correctness of the information contained herein. No liability is assumed for errors or misprints.

Due to the high quality of our product, we grant you a 2-year warranty. The function and durability of the central lock control unit depends to a large degree on appropriate mounting. Understandably, we cannot grant any warranty for defects ascribable to wrong or erroneous mounting. In particular, these include charred or burnt components.

Reconsignment of seemingly defective components is categorically at the customer's expense. Trouble shooting is only possible provided that a description of the defect and a copy of the invoice are enclosed. Please note that handling or connecting errors are outside the scope of this warranty. Understandably, we cannot assume liability for defects thus caused.

We grant a 2-year warranty from date of purchase on all components. Warranty includes free of charge trouble shooting of those defects verifiably ascribable to the use of faulty material or to manufacturing errors. All other claims are exempt from liability.

No responsibility or liability is taken for damages or consequential loss relating to this product. Repairation, amendments, supply of spare parts and refunding of purchase price are reserved.

Warranty expires if:

- 1) the device has been altered or if attempts at repairing the device have been made.
- 2) the device has been surcharged.
- 3) damages have come about due to the ignoring of mounting instructions.
- 4) the device has been connected to inadequate current or voltage.
- 5) the appropriate polarity of the device has not been observed.
- 6) the device has been damaged due to maloperation.
- 7) the device has been damaged due to negligent handling.
- 8) the device has been damaged due to by-passed or wrong fuses.

Key alteration:

The blank keys that are screwed into the handheld transmitters only serve as samples (models). You have to have your own car key modified according to this model and screw it onto the transmitter. You may decide for yourself whether you want to use your original car key or have a copy cut in order to have it modified.

Immobilizer:

The immobilizer transponder chip has to be stuck into the handheld transmitter (above the LED).

Receiver

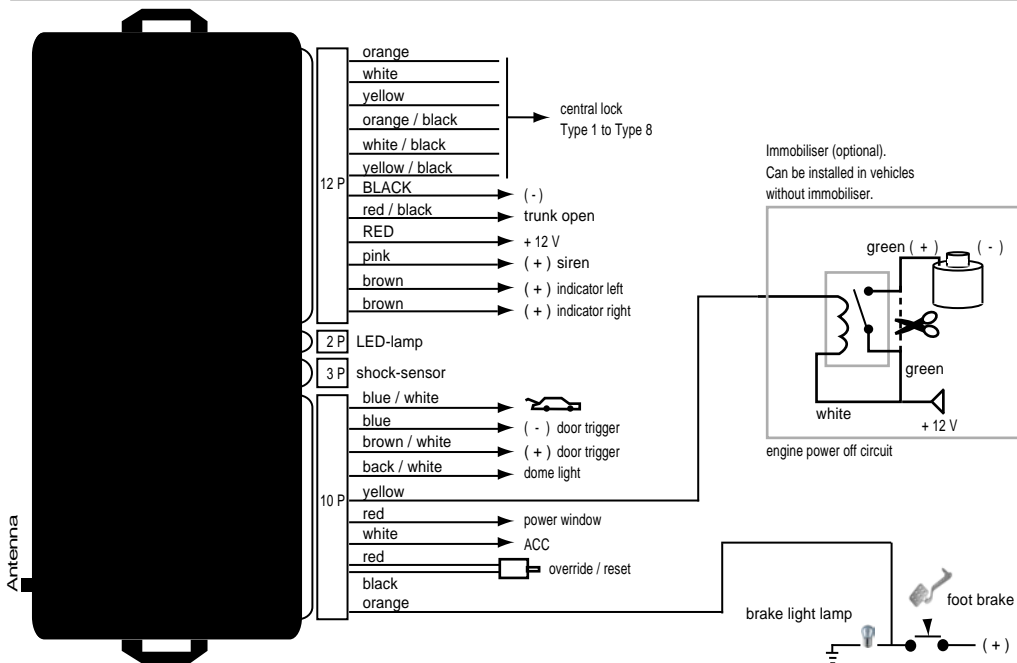

■ Type 1

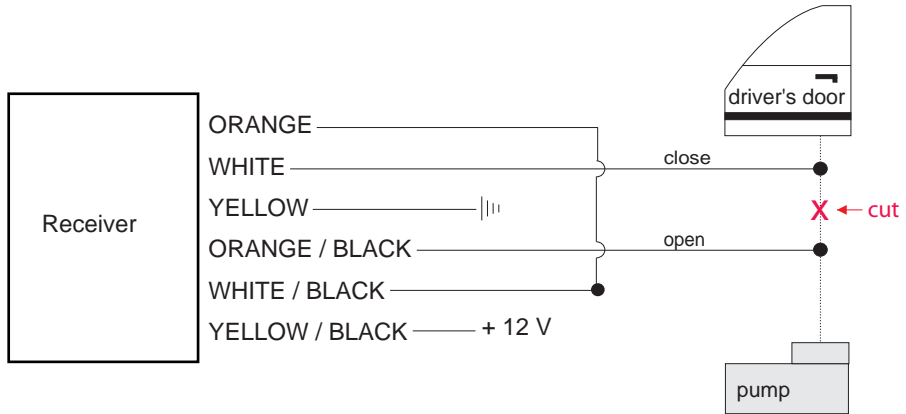

| ||| GROUND

■ Type 2



||| GROUND

■ not required, please insulate

■ Type 3



■ not required, please insulate

■ Type 4



■ Type 5: (Pin)



■ not required, please insulate

■ Type 6: (with resistance)



||| GROUND

■ not required, please insulate

■ Type 7



||| GROUND

■ not required, please insulate

■ Type 8: (actuator)



||| GROUND

Fiat

Model

500 Sporting

Year of construction

96->

Code

-

WIRE COLOUR / POSITION

Turn signal left

blue

Turn signal right

blue-black

Turn signal position

At the turn signal switch, in the wires left to the rear or also directly at the tail lamps.

Car lock type

Type2

Car lock open

white-yellow

Car lock close

blue-red

Car lock position

Wiring harness coming from driver's door.

Fiat

Model	Year of construction	Code
Barchetta	95->	-

WIRE COLOUR / POSITION

Turn signal left	blue
Turn signal right	blue-black
Turn signal position	At the turn signal switch, in the wires left to the rear or also directly at the tail lamps.
Car lock type	Type2
Car lock open	blue
Car lock close	white
Car lock position	Wiring harness coming from driver's door.

Fiat

Model

Brava

Year of construction

96->

Code

-

WIRE COLOUR / POSITION

Turn signal left

blue-black

Turn signal right

blue

Turn signal position

At the turn signal switch, in the wires left to the rear or also directly at the tail lamps.

Car lock type

Type2

Car lock open

blue

Car lock close

white

Car lock position

Wiring harness coming from driver's door.

Fiat

Model

Bravo

Year of construction

96->

Code

-

WIRE COLOUR / POSITION

Turn signal left

blue-black

Turn signal right

blue

Turn signal position

At the turn signal switch, in the wires left to the rear or also directly at the tail lamps.

Car lock type

Type2

Car lock open

blue

Car lock close

white

Car lock position

Wiring harness coming from driver's door.

Fiat

Model	Year of construction	Code
Cinquecento	96->	-

WIRE COLOUR / POSITION

Turn signal left	blue
Turn signal right	blue-black
Turn signal position	At the turn signal switch, in the wires left to the rear or also directly at the tail lamps.
Car lock type	Type2
Car lock open	white
Car lock close	blue
Car lock position	Wiring harness coming from driver's door.

Fiat

Model

Coupe

Year of construction

97->

Code

-

WIRE COLOUR / POSITION

Turn signal left

blue

Turn signal right

blue-black

Turn signal position

At the turn signal switch, in the wires left to the rear or also directly at the tail lamps.

Car lock type

Type2

Car lock open

white

Car lock close

blue

Car lock position

Wiring harness coming from driver's door.

Fiat

Model

Croma

Year of construction

95->

Code

-

WIRE COLOUR / POSITION

Turn signal left

blue-white

Turn signal right

blue-black

Turn signal position

At the turn signal switch, in the wires left to the rear or also directly at the tail lamps.

Car lock type

Type2

Car lock open

white

Car lock close

blue

Car lock position

Wiring harness coming from driver's door.

Fiat

Model

Doblo

Year of construction

->04

Code

-

WIRE COLOUR / POSITION

Turn signal left

pink-white

Turn signal right

pink

Turn signal position

At the turn signal switch, in the wires left to the rear or also directly at the tail lamps.

Car lock type

Type2

Car lock open

blue-light blue

Car lock close

brown-white

Car lock position

40-pin plug at the fuse box.

Fiat

Model

Marea

Year of construction

97->

Code

-

WIRE COLOUR / POSITION

Turn signal left

blue

Turn signal right

blue-black

Turn signal position

At the turn signal switch, in the wires left to the rear or also directly at the tail lamps.

Car lock type

Type2

Car lock open

white

Car lock close

blue

Car lock position

Wiring harness coming from driver's door.

Fiat

Model

Palio

Year of construction

98->

Code

-

WIRE COLOUR / POSITION

Turn signal left

white-black

Turn signal right

white-blue

Turn signal position

At the turn signal switch, in the wires left to the rear or also directly at the tail lamps.

Car lock type

Type2

Car lock open

blue

Car lock close

white

Car lock position

Wiring harness coming from driver's door.

Fiat

Model	Year of construction	Code
Panda	-	-

WIRE COLOUR / POSITION

Turn signal left	blue
Turn signal right	blue-black
Turn signal position	At the turn signal switch, in the wires left to the rear or also directly at the tail lamps.
Car lock type	Type2
Car lock open	blue
Car lock close	white
Car lock position	Wiring harness coming from driver's door.

Fiat

Model

Punto

Year of construction

99->

Code

-

WIRE COLOUR / POSITION

Turn signal left

pink

Turn signal right

pink-white

Turn signal position

At the turn signal switch, in the wires left to the rear or also directly at the tail lamps.

Car lock type

Type2

Car lock open

blue-purple (pin 24)

Car lock close

white-green (pin 34)

Car lock position

40-pin plug at the fuse box.

Fiat

Model

Punto

Year of construction

96->

Code

-

WIRE COLOUR / POSITION

Turn signal left

blue

Turn signal right

blue-black

Turn signal position

At the turn signal switch, in the wires left to the rear or also directly at the tail lamps.

Car lock type

Type2

Car lock open

white

Car lock close

blue

Car lock position

Wiring harness coming from driver's door.

Fiat

Model

Seicento

Year of construction

96->

Code

-

WIRE COLOUR / POSITION

Turn signal left

blue

Turn signal right

blue-black

Turn signal position

At the turn signal switch, in the wires left to the rear or also directly at the tail lamps.

Car lock type

Type2

Car lock open

white-yellow

Car lock close

blue-red

Car lock position

Wiring harness coming from driver's door.

Fiat

Model

Tempra

Year of construction

92->

Code

-

WIRE COLOUR / POSITION

Turn signal left

light blue

Turn signal right

light blue-black

Turn signal position

At the turn signal switch, in the wires left to the rear or also directly at the tail lamps.

Car lock type

Type2

Car lock open

white

Car lock close

light blue

Car lock position

Wiring harness coming from driver's door.

Fiat

Model

Typo

Year of construction

91-93

Code

-

WIRE COLOUR / POSITION

Turn signal left

blue

Turn signal right

blue-black

Turn signal position

At the turn signal switch, in the wires left to the rear or also directly at the tail lamps.

Car lock type

Type2

Car lock open

white

Car lock close

blue

Car lock position

Wiring harness coming from driver's door.

Fiat

Model

Ulysse

Year of construction

95->

Code

-

WIRE COLOUR / POSITION

Turn signal left

green

Turn signal right

green

Turn signal position

At the turn signal switch, in the wires left to the rear or also directly at the tail lamps.

Car lock type

Type2

Car lock open

orange 628

Car lock close

orange 627

Car lock position

Wiring harness coming from driver's door.

Fiat

Model

Ulysse

Year of construction

96->

Code

-

WIRE COLOUR / POSITION

Turn signal left

green 2346

Turn signal right

green 2333

Turn signal position

At the turn signal switch, in the wires left to the rear or also directly at the tail lamps.

Car lock type

Type2

Car lock open

orange 6290

Car lock close

orange 6291

Car lock position

23-pin plug (black) under driver foot carpet.

Fiat

Model

Uno

Year of construction

96->

Code

-

WIRE COLOUR / POSITION

Turn signal left

blue

Turn signal right

blue-black

Turn signal position

At the turn signal switch, in the wires left to the rear or also directly at the tail lamps.

Car lock type

Type2

Car lock open

white

Car lock close

blue

Car lock position

Wiring harness coming from driver's door.