

RCA 101

Car Alarm &
Radio Remote Control
with turn signal triggering

Mounting Instructions

Mazda



■ Warranty

No responsibility is taken for the correctness of the information contained herein. No liability is assumed for errors or misprints.

Due to the high quality of our product, we grant you a 2-year warranty. The function and durability of the central lock control unit depends to a large degree on appropriate mounting. Understandably, we cannot grant any warranty for defects ascribable to wrong or erroneous mounting. In particular, these include charred or burnt components.

Reconsignment of seemingly defective components is categorically at the customer's expense. Trouble shooting is only possible provided that a description of the defect and a copy of the invoice are enclosed. Please note that handling or connecting errors are outside the scope of this warranty. Understandably, we cannot assume liability for defects thus caused.

We grant a 2-year warranty from date of purchase on all components. Warranty includes free of charge trouble shooting of those defects verifiably ascribable to the use of faulty material or to manufacturing errors. All other claims are exempt from liability.

No responsibility or liability is taken for damages or consequential loss relating to this product. Repairation, amendments, supply of spare parts and refunding of purchase price are reserved.

Warranty expires if:

- 1) the device has been altered or if attempts at repairing the device have been made.
- 2) the device has been surcharged.
- 3) damages have come about due to the ignoring of mounting instructions.
- 4) the device has been connected to inadequate current or voltage.
- 5) the appropriate polarity of the device has not been observed.
- 6) the device has been damaged due to maloperation.
- 7) the device has been damaged due to negligent handling.
- 8) the device has been damaged due to by-passed or wrong fuses.

Key alteration:

The blank keys that are screwed into the handheld transmitters only serve as samples (models). You have to have your own car key modified according to this model and screw it onto the transmitter. You may decide for yourself whether you want to use your original car key or have a copy cut in order to have it modified.

Immobilizer:

The immobilizer transponder chip has to be stuck into the handheld transmitter (above the LED).

Receiver

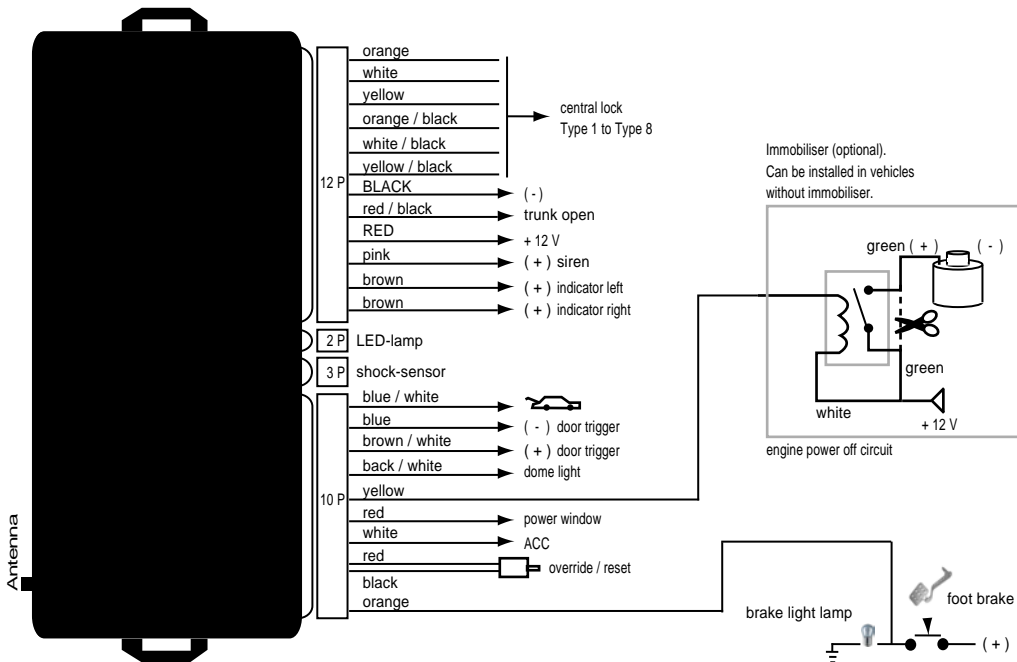

■ Type 1



||| GROUND

■ Type 2



||| GROUND

■ not required, please insulate

■ Type 3



[] not required, please insulate

■ Type 4



■ Type 5: (Pin)



■ not required, please insulate

■ Type 6: (with resistance)



||| GROUND

■ not required, please insulate

■ Type 7



||| GROUND

■ not required, please insulate

■ Type 8: (actuator)



| | | GROUND

Mazda

Model

121

Year of construction

93->

Code

-

WIRE COLOUR / POSITION

Turn signal left

blue or green-white

Turn signal right

blue-red or green-black

Turn signal position

At the turn signal switch, in the wires left to the rear or also directly at the tail lamps.

Car lock type

Type3

Car lock open

yellow-black

Car lock close

white-purple

Car lock position

Wiring harness coming from driver's door.

Mazda

Model

323

Year of construction

92->

Code

BA/F

WIRE COLOUR / POSITION

Turn signal left

green-black or green-red

Turn signal right

green-white or brown-red

Turn signal position

At the turn signal switch, in the wires left to the rear or also directly at the tail lamps.

Car lock type

Type2

Car lock open

grey-white or green-white

Car lock close

green-red

Car lock position

Wiring harness coming from driver's door.

Mazda

Model

323 Lantis

Year of construction

95->

Code

-

WIRE COLOUR / POSITION

Turn signal left

green-black

Turn signal right

green-white

Turn signal position

At the turn signal switch, in the wires left to the rear or also directly at the tail lamps.

Car lock type

Type2

Car lock open

grey-white or green-white

Car lock close

green-red

Car lock position

Wiring harness coming from driver's door.

Mazda

Model

323F

Year of construction

92->

Code

-

WIRE COLOUR / POSITION

Turn signal left

green-black

Turn signal right

green-white

Turn signal position

At the turn signal switch, in the wires left to the rear or also directly at the tail lamps.

Car lock type

Type2

Car lock open

green-white

Car lock close

green-red

Car lock position

Wiring harness coming from driver's door.

Mazda

Model

626

Year of construction

92->

Code

-

WIRE COLOUR / POSITION

Turn signal left

green-white-silver

Turn signal right

green-black-silver

Turn signal position

At the turn signal switch, in the wires left to the rear or also directly at the tail lamps.

Car lock type

Type2

Car lock open

brown-grey

Car lock close

brown-yellow-green

Car lock position

Wiring harness coming from driver's door.

Mazda

Model

626

Year of construction

1997

Code

-

WIRE COLOUR / POSITION

Turn signal left

green-black-grey

Turn signal right

green-white-grey

Turn signal position

At the turn signal switch, in the wires left to the rear or also directly at the tail lamps.

Car lock type

Type2

Car lock open

brown-silver

Car lock close

brown-yellow-silver

Car lock position

Wiring harness coming from driver's door.

Mazda

Model

626

Year of construction

88-92

Code

-

WIRE COLOUR / POSITION

Turn signal left

green-white

Turn signal right

green-black

Turn signal position

At the turn signal switch, in the wires left to the rear or also directly at the tail lamps.

Car lock type

Type8

Car lock open

-

Car lock close

-

Car lock position

Actuator must be installed in the driver's door.

Mazda

Model

626

Year of construction

2001->

Code

WIRE COLOUR / POSITION

Turn signal left

green-red

Turn signal right

green-white

Turn signal position

At the turn signal switch, in the wires left to the rear or also directly at the tail lamps.

Car lock type

Type2

Car lock open

brown-white

Car lock close

brown-yellow

Car lock position

Wiring harness coming from driver's door.

Mazda

Model

626

Year of construction

1998-2001

Code

WIRE COLOUR / POSITION

Turn signal left

green-black

Turn signal right

green-white

Turn signal position

At the turn signal switch, in the wires left to the rear or also directly at the tail lamps.

Car lock type

Type2

Car lock open

white-black

Car lock close

grey-red

Car lock position

Wiring harness coming from driver's door.

Mazda

Model	Year of construction	Code
Demio	99->	-

WIRE COLOUR / POSITION

Turn signal left	green-black
Turn signal right	green-white
Turn signal position	At the turn signal switch, in the wires left to the rear or also directly at the tail lamps.
Car lock type	Type8
Car lock open	-
Car lock close	-
Car lock position	Actuator must be installed in the driver's door.

Mazda

Model	Year of construction	Code
MPV Di	97->	-

WIRE COLOUR / POSITION

Turn signal left	green-black-silver
Turn signal right	green-white-silver
Turn signal position	At the turn signal switch, in the wires left to the rear or also directly at the tail lamps.
Car lock type	Type8
Car lock open	-
Car lock close	-
Car lock position	Actuator must be installed in the driver's door.

Mazda

Model	Year of construction	Code
MX 3	93->	-

WIRE COLOUR / POSITION

Turn signal left	green-white
Turn signal right	green-black
Turn signal position	At the turn signal switch, in the wires left to the rear or also directly at the tail lamps.
Car lock type	Type8
Car lock open	-
Car lock close	-
Car lock position	Actuator must be installed in the driver's door.

Mazda

Model

MX 5

Year of construction

99->

Code

-

WIRE COLOUR / POSITION

Turn signal left

green-white

Turn signal right

green-black

Turn signal position

At the turn signal switch, in the wires left to the rear or also directly at the tail lamps.

Car lock type

Type3

Car lock open

red-yellow

Car lock close

blue-yellow

Car lock position

Wiring harness coming from driver's door.

Mazda

Model	Year of construction	Code
MX 5	93->	-

WIRE COLOUR / POSITION

Turn signal left	green-white
Turn signal right	green-black
Turn signal position	At the turn signal switch, in the wires left to the rear or also directly at the tail lamps.
Car lock type	Type8
Car lock open	-
Car lock close	-
Car lock position	Actuator must be installed in the driver's door.

Mazda

Model	Year of construction	Code
MX 6	93->	-

WIRE COLOUR / POSITION

Turn signal left	green-white
Turn signal right	green-black
Turn signal position	At the turn signal switch, in the wires left to the rear or also directly at the tail lamps.
Car lock type	Type2
Car lock open	green-orange
Car lock close	purple
Car lock position	Wiring harness coming from driver's door.

Mazda

Model

Xedos

Year of construction

95->

Code

-

WIRE COLOUR / POSITION

Turn signal left

green-white

Turn signal right

green-black

Turn signal position

At the turn signal switch, in the wires left to the rear or also directly at the tail lamps.

Car lock type

Type2

Car lock open

brown-black

Car lock close

brown-white

Car lock position

Wiring harness coming from driver's door.

Mazda

Model

Xedos 6

Year of construction

96->

Code

-

WIRE COLOUR / POSITION

Turn signal left

green-black

Turn signal right

green-white

Turn signal position

At the turn signal switch, in the wires left to the rear or also directly at the tail lamps.

Car lock type

Type2

Car lock open

green-orange

Car lock close

black-orange

Car lock position

Central module (passenger side).