

RCA 100

Car Alarm &
Radio Remote Control
with turn signal triggering

Mounting Instructions

Mercedes



■ Warranty

No responsibility is taken for the correctness of the information contained herein. No liability is assumed for errors or misprints.

Due to the high quality of our product, we grant you a 2-year warranty. The function and durability of the central lock control unit depends to a large degree on appropriate mounting. Understandably, we cannot grant any warranty for defects ascribable to wrong or erroneous mounting. In particular, these include charred or burnt components.

Reconsignment of seemingly defective components is categorically at the customer's expense. Trouble shooting is only possible provided that a description of the defect and a copy of the invoice are enclosed. Please note that handling or connecting errors are outside the scope of this warranty. Understandably, we cannot assume liability for defects thus caused.

We grant a 2-year warranty from date of purchase on all components. Warranty includes free of charge trouble shooting of those defects verifiably ascribable to the use of faulty material or to manufacturing errors. All other claims are exempt from liability.

No responsibility or liability is taken for damages or consequential loss relating to this product. Repairation, amendments, supply of spare parts and refunding of purchase price are reserved.

Warranty expires if:

- 1) the device has been altered or if attempts at repairing the device have been made.
- 2) the device has been surcharged.
- 3) damages have come about due to the ignoring of mounting instructions.
- 4) the device has been connected to inadequate current or voltage.
- 5) the appropriate polarity of the device has not been observed.
- 6) the device has been damaged due to maloperation.
- 7) the device has been damaged due to negligent handling.
- 8) the device has been damaged due to by-passed or wrong fuses.

Key alteration:

The blank keys that are screwed into the handheld transmitters only serve as samples (models). You have to have your own car key modified according to this model and screw it onto the transmitter. You may decide for yourself whether you want to use your original car key or have a copy cut in order to have it modified.

Immobilizer:

The immobilizer transponder chip has to be stuck into the handheld transmitter (above the LED).

Receiver



■ Type 1

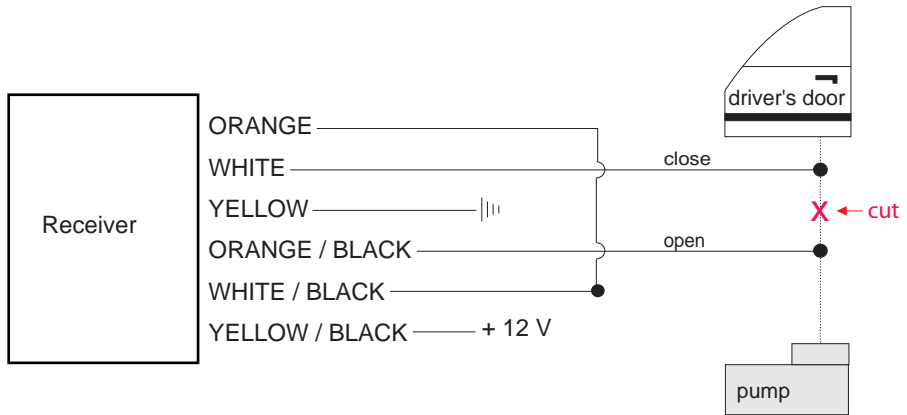

| ||| GROUND

■ Type 2



||| GROUND

■ not required, please insulate

■ Type 3



[] not required, please insulate

■ Type 4



■ Type 5: (Pin)



■ not required, please insulate

■ Type 6: (with resistance)



||| GROUND

■ not required, please insulate

■ Type 7



||| GROUND

■ not required, please insulate

■ Type 8: (actuator)



||| GROUND

Mercedes

Model

190

Year of construction

91->

Code

W201

WIRE COLOUR / POSITION

Turn signal left

black-white

Turn signal right

black-green

Turn signal position

At the turn signal switch, in the wires left to the rear or also directly at the tail lamps.

Car lock type

Type1

Car lock open

blue

Car lock close

blue

Car lock position

Directly at the central lock pump under the back seat.

Mercedes

| Model | Year of construction | Code |
|---------|----------------------|------|
| 200-500 | 95-> | W124 |

WIRE COLOUR / POSITION

| | |
|----------------------|--|
| Turn signal left | black-white |
| Turn signal right | black-green |
| Turn signal position | At the turn signal switch, in the wires left to the rear or also directly at the tail lamps. |
| Car lock type | Type1 |
| Car lock open | blue |
| Car lock close | blue |
| Car lock position | Directly at the central lock pump under the back seat. |

Mercedes

| Model | Year of construction | Code |
|-------------|----------------------|------|
| 260WE-560WE | 91-> | W126 |

WIRE COLOUR / POSITION

| | |
|----------------------|--|
| Turn signal left | black-white |
| Turn signal right | black-green |
| Turn signal position | At the turn signal switch, in the wires left to the rear or also directly at the tail lamps. |
| Car lock type | Type1 |
| Car lock open | blue |
| Car lock close | blue |
| Car lock position | Directly at the central lock pump under the back seat. |

Mercedes

| Model | Year of construction | Code |
|---------|----------------------|------|
| A-class | 97-> | W168 |

WIRE COLOUR / POSITION

| | |
|----------------------|--|
| Turn signal left | black-white |
| Turn signal right | black-green |
| Turn signal position | At the turn signal switch, in the wires left to the rear or also directly at the tail lamps. |
| Car lock type | Type2 |
| Car lock open | blue |
| Car lock close | black |
| Car lock position | Wiring harness coming from driver's door. |

Mercedes

| Model | Year of construction | Code |
|----------|----------------------|------|
| C180-280 | 94-> | W202 |

WIRE COLOUR / POSITION

| | |
|----------------------|--|
| Turn signal left | black-white |
| Turn signal right | black-green |
| Turn signal position | At the turn signal switch, in the wires left to the rear or also directly at the tail lamps. |
| Car lock type | Type2 |
| Car lock open | blue |
| Car lock close | black |
| Car lock position | Central lock pump in the trunk (right). |

Mercedes

| Model | Year of construction | Code |
|-------|----------------------|------|
| CLK | 97-> | C208 |

WIRE COLOUR / POSITION

| | |
|----------------------|--|
| Turn signal left | black-white |
| Turn signal right | black-green |
| Turn signal position | At the turn signal switch, in the wires left to the rear or also directly at the tail lamps. |
| Car lock type | Type6 |
| Car lock open | white-green |
| Car lock close | white-green with 200 ohm resistance |
| Car lock position | Wiring harness coming from driver's door. |

Mercedes

| Model | Year of construction | Code |
|----------|----------------------|------|
| E200-420 | 95-> | W210 |

WIRE COLOUR / POSITION

| | |
|----------------------|--|
| Turn signal left | black-white |
| Turn signal right | black-green |
| Turn signal position | At the turn signal switch, in the wires left to the rear or also directly at the tail lamps. |
| Car lock type | Type6 |
| Car lock open | white-green |
| Car lock close | white-green with 200 ohm resistance |
| Car lock position | Under the back seat. |

Mercedes

Model

G230-300

Year of construction

91->

Code

W460

WIRE COLOUR / POSITION

Turn signal left

black-white

Turn signal right

black-green

Turn signal position

At the turn signal switch, in the wires left to the rear or also directly at the tail lamps.

Car lock type

Type2

Car lock open

brown-white

Car lock close

brown-blue

Car lock position

Wiring harness coming from driver's door.

Mercedes

| Model | Year of construction | Code |
|---------|----------------------|------|
| S-class | 99-> | W140 |

WIRE COLOUR / POSITION

| | |
|----------------------|--|
| Turn signal left | black-white |
| Turn signal right | black-green |
| Turn signal position | At the turn signal switch, in the wires left to the rear or also directly at the tail lamps. |
| Car lock type | Type2 |
| Car lock open | blue-black |
| Car lock close | blue-yellow |
| Car lock position | Wiring harness coming from driver's door. |

Mercedes

| Model | Year of construction | Code |
|---------|----------------------|------|
| S-class | ->91 | W12 |

WIRE COLOUR / POSITION

| | |
|----------------------|--|
| Turn signal left | black-white |
| Turn signal right | black-green |
| Turn signal position | At the turn signal switch, in the wires left to the rear or also directly at the tail lamps. |
| Car lock type | Type1 |
| Car lock open | blue or green |
| Car lock close | blue or green |
| Car lock position | Directly at the central lock pump. |

Mercedes

| Model | Year of construction | Code |
|-------|----------------------|------|
| SL | 89-> | R129 |

WIRE COLOUR / POSITION

| | |
|----------------------|--|
| Turn signal left | black-white |
| Turn signal right | black-green |
| Turn signal position | At the turn signal switch, in the wires left to the rear or also directly at the tail lamps. |
| Car lock type | Type1 |
| Car lock open | blue |
| Car lock close | blue |
| Car lock position | Directly at the central lock pump. |

Mercedes

| Model | Year of construction | Code |
|-------|----------------------|------|
| SLK | 96-> | R170 |

WIRE COLOUR / POSITION

| | |
|----------------------|--|
| Turn signal left | black-white |
| Turn signal right | black-green |
| Turn signal position | At the turn signal switch, in the wires left to the rear or also directly at the tail lamps. |
| Car lock type | Type6 |
| Car lock open | white-green |
| Car lock close | white-green with 200 ohm resistance |
| Car lock position | Wiring harness coming from driver's door. |

Mercedes

| Model | Year of construction | Code |
|----------|----------------------|------|
| Sprinter | 2000-> | - |

WIRE COLOUR / POSITION

| | |
|----------------------|--|
| Turn signal left | black-white |
| Turn signal right | black-green |
| Turn signal position | At the turn signal switch, in the wires left to the rear or also directly at the tail lamps. |
| Car lock type | Type2 |
| Car lock open | pin 5 |
| Car lock close | pin 7 |
| Car lock position | At the plug at the controller under the driver's seat. |

Mercedes

| Model | Year of construction | Code |
|----------|----------------------|------|
| Sprinter | 97-> | - |

WIRE COLOUR / POSITION

| | |
|----------------------|--|
| Turn signal left | black-white |
| Turn signal right | black-green |
| Turn signal position | At the turn signal switch, in the wires left to the rear or also directly at the tail lamps. |
| Car lock type | Type2 |
| Car lock open | green-white |
| Car lock close | blue-red |
| Car lock position | At the controller under the driver's seat. |

Mercedes

| Model | Year of construction | Code |
|---------|----------------------|------|
| V-class | 96-> | 638 |

WIRE COLOUR / POSITION

| | |
|----------------------|--|
| Turn signal left | black-white |
| Turn signal right | black-green |
| Turn signal position | At the turn signal switch, in the wires left to the rear or also directly at the tail lamps. |
| Car lock type | Type2 |
| Car lock open | blue-black |
| Car lock close | blue-yellow |
| Car lock position | Wiring harness coming from driver's door. |

Mercedes

| Model | Year of construction | Code |
|-------|----------------------|------|
| Vito | 98-> | - |

WIRE COLOUR / POSITION

| | |
|----------------------|--|
| Turn signal left | black-white |
| Turn signal right | black-green |
| Turn signal position | At the turn signal switch, in the wires left to the rear or also directly at the tail lamps. |
| Car lock type | Type3 |
| Car lock open | green-black |
| Car lock close | blue-red |
| Car lock position | Wiring harness coming from driver's door. |