

RCA 101

Car Alarm &
Radio Remote Control
with turn signal triggering

Mounting Instructions

Renault



■ Warranty

No responsibility is taken for the correctness of the information contained herein. No liability is assumed for errors or misprints.

Due to the high quality of our product, we grant you a 2-year warranty. The function and durability of the central lock control unit depends to a large degree on appropriate mounting. Understandably, we cannot grant any warranty for defects ascribable to wrong or erroneous mounting. In particular, these include charred or burnt components.

Reconsignment of seemingly defective components is categorically at the customer's expense. Trouble shooting is only possible provided that a description of the defect and a copy of the invoice are enclosed. Please note that handling or connecting errors are outside the scope of this warranty. Understandably, we cannot assume liability for defects thus caused.

We grant a 2-year warranty from date of purchase on all components. Warranty includes free of charge trouble shooting of those defects verifiably ascribable to the use of faulty material or to manufacturing errors. All other claims are exempt from liability.

No responsibility or liability is taken for damages or consequential loss relating to this product. Repairation, amendments, supply of spare parts and refunding of purchase price are reserved.

Warranty expires if:

- 1) the device has been altered or if attempts at repairing the device have been made.
- 2) the device has been surcharged.
- 3) damages have come about due to the ignoring of mounting instructions.
- 4) the device has been connected to inadequate current or voltage.
- 5) the appropriate polarity of the device has not been observed.
- 6) the device has been damaged due to maloperation.
- 7) the device has been damaged due to negligent handling.
- 8) the device has been damaged due to by-passed or wrong fuses.

Key alteration:

The blank keys that are screwed into the handheld transmitters only serve as samples (models). You have to have your own car key modified according to this model and screw it onto the transmitter. You may decide for yourself whether you want to use your original car key or have a copy cut in order to have it modified.

Immobilizer:

The immobilizer transponder chip has to be stuck into the handheld transmitter (above the LED).

Receiver

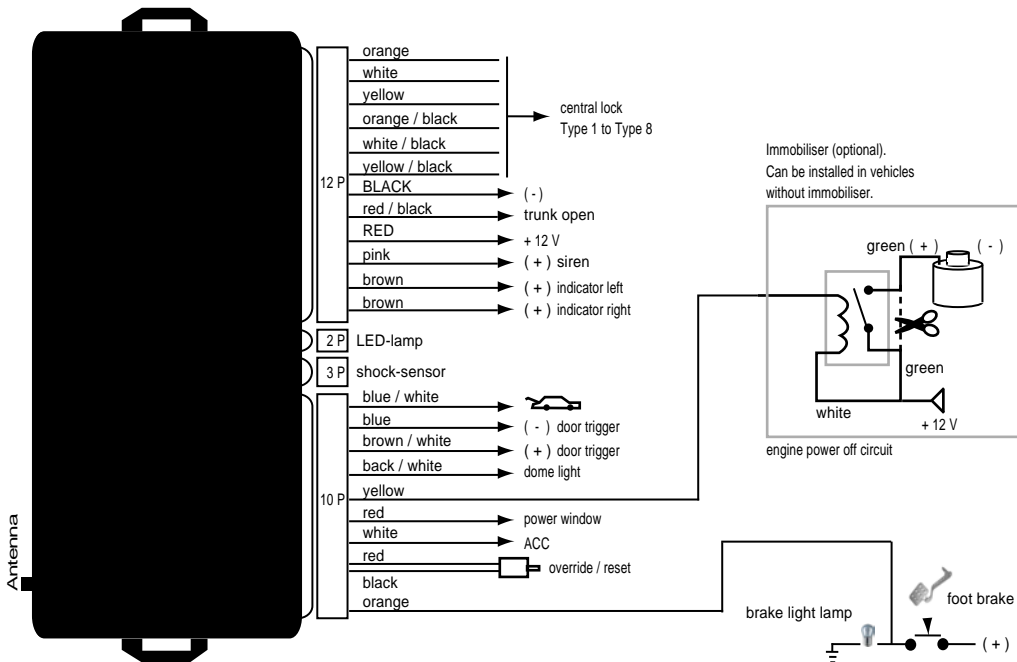

■ Type 1



||| GROUND

■ Type 2

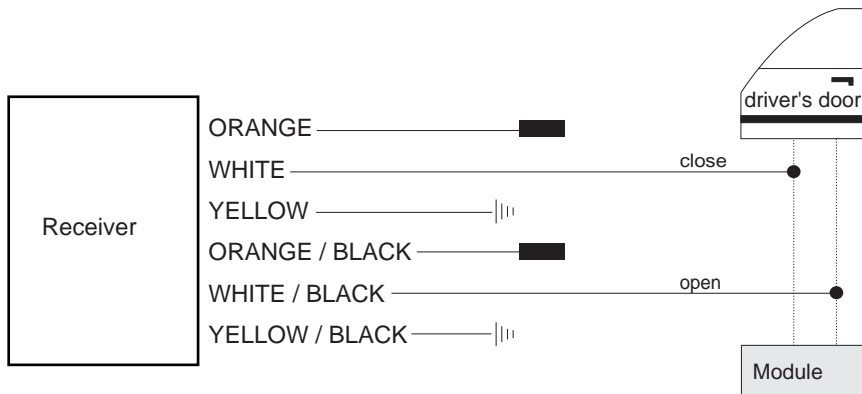

||| GROUND

■ not required, please insulate

■ Type 3



■ not required, please insulate

■ Type 4



■ Type 5: (Pin)



■ not required, please insulate

■ Type 6: (with resistance)



||| GROUND

■ not required, please insulate

■ Type 7



||| GROUND

■ not required, please insulate

■ Type 8: (actuator)



||| GROUND

Renault

Model

19

Year of construction

92->

Code

-

WIRE COLOUR / POSITION

Turn signal left

purple or white-grey-black

Turn signal right

orange or green-grey

Turn signal position

At the turn signal switch, in the wires left to the rear or also directly at the tail lamps.

Car lock type

Type3

Car lock open

white or white-green

Car lock close

purple or green

Car lock position

Wiring harness coming from driver's door.

Renault

Model	Year of construction	Code
21	90->	-

WIRE COLOUR / POSITION

Turn signal left	white
Turn signal right	white
Turn signal position	At the turn signal switch, in the wires left to the rear or also directly at the tail lamps.
Car lock type	Type3
Car lock open	brown-green
Car lock close	brown
Car lock position	Wiring harness coming from driver's door.

Renault

Model	Year of construction	Code
21	91->	-

WIRE COLOUR / POSITION

Turn signal left	green
Turn signal right	green-brown
Turn signal position	At the turn signal switch, in the wires left to the rear or also directly at the tail lamps.
Car lock type	Type3
Car lock open	purple
Car lock close	white
Car lock position	Wiring harness coming from driver's door.

Renault

Model

25

Year of construction

90->

Code

-

WIRE COLOUR / POSITION

Turn signal left

white

Turn signal right

white

Turn signal position

At the turn signal switch, in the wires left to the rear or also directly at the tail lamps.

Car lock type

Type3

Car lock open

yellow-blue

Car lock close

yellow-green

Car lock position

Wiring harness coming from driver's door.

Renault

Model

Clio

Year of construction

91-93

Code

-

WIRE COLOUR / POSITION

Turn signal left

brown

Turn signal right

orange

Turn signal position

At the turn signal switch, in the wires left to the rear or also directly at the tail lamps.

Car lock type

Type3

Car lock open

brown, needs double impulse to open

Car lock close

orange

Car lock position

Wiring harness coming from driver's door.

Renault

Model

Clio 2

Year of construction

98->

Code

-

WIRE COLOUR / POSITION

Turn signal left

purple-brown

Turn signal right

pink-brown

Turn signal position

At the turn signal switch, in the wires left to the rear or also directly at the tail lamps.

Car lock type

Type2

Car lock open

grey

Car lock close

pink

Car lock position

Wiring harness coming from driver's door.

Renault

Model	Year of construction	Code
Clio Nouvelle	96->	-

WIRE COLOUR / POSITION

Turn signal left	brown
Turn signal right	orange
Turn signal position	At the turn signal switch, in the wires left to the rear or also directly at the tail lamps.
Car lock type	Type3
Car lock open	pink-grey
Car lock close	white-grey
Car lock position	Wiring harness coming from driver's door.

Renault

Model	Year of construction	Code
Clio1,8i	96->	-

WIRE COLOUR / POSITION

Turn signal left	brown
Turn signal right	orange
Turn signal position	At the turn signal switch, in the wires left to the rear or also directly at the tail lamps.
Car lock type	Type2
Car lock open	pink
Car lock close	white
Car lock position	Wiring harness coming from driver's door.

Renault

Model

Espace

Year of construction

90->

Code

WIRE COLOUR / POSITION

Turn signal left

white-green

Turn signal right

white-black

Turn signal position

At the turn signal switch, in the wires left to the rear or also directly at the tail lamps.

Car lock type

Type3

Car lock open

orange-blue

Car lock close

orange

Car lock position

Wiring harness coming from driver's door.

Renault

Model

Espace

Year of construction

92->

Code

WIRE COLOUR / POSITION

Turn signal left

brown-white

Turn signal right

orange-white

Turn signal position

At the turn signal switch, in the wires left to the rear or also directly at the tail lamps.

Car lock type

Type3

Car lock open

orange-green

Car lock close

brown-green

Car lock position

Wiring harness coming from driver's door.

Renault

Model

Espace

Year of construction

92->

Code

WIRE COLOUR / POSITION

Turn signal left

brown-white

Turn signal right

orange-white

Turn signal position

At the turn signal switch, in the wires left to the rear or also directly at the tail lamps.

Car lock type

Type3

Car lock open

green

Car lock close

brown-green

Car lock position

Wiring harness coming from driver's door.

Renault

Model	Year of construction	Code
Espace	97->	

WIRE COLOUR / POSITION

Turn signal left	white-red
Turn signal right	pink
Turn signal position	At the turn signal switch, in the wires left to the rear or also directly at the tail lamps.
Car lock type	Type2
Car lock open	white-orange
Car lock close	yellow-orange
Car lock position	Wiring harness coming from driver's door.

Renault

Model

Espress D65

Year of construction

96->

Code

WIRE COLOUR / POSITION

Turn signal left

white

Turn signal right

grey

Turn signal position

At the turn signal switch, in the wires left to the rear or also directly at the tail lamps.

Car lock type

Type3

Car lock open

pink-grey

Car lock close

white

Car lock position

Wiring harness coming from driver's door.

Renault

Model	Year of construction	Code
Kangoo	97->	

WIRE COLOUR / POSITION

Turn signal left	orange
Turn signal right	brown
Turn signal position	At the turn signal switch, in the wires left to the rear or also directly at the tail lamps.
Car lock type	Type2
Car lock open	orange
Car lock close	brown
Car lock position	Wiring harness coming from driver's door.

Renault

Model

Laguna

Year of construction

95->

Code

WIRE COLOUR / POSITION

Turn signal left

purple-grey

Turn signal right

green-grey

Turn signal position

At the turn signal switch, in the wires left to the rear or also directly at the tail lamps.

Car lock type

Type2

Car lock open

orange

Car lock close

purple or purple-grey

Car lock position

Wiring harness coming from driver's door.

Renault

Model

Megane

Year of construction

96->

Code

WIRE COLOUR / POSITION

Turn signal left

brown

Turn signal right

brown

Turn signal position

At the turn signal switch, in the wires left to the rear or also directly at the tail lamps.

Car lock type

Type2

Car lock open

pink

Car lock close

purple

Car lock position

Wiring harness coming from driver's door.

Renault

Model

Megane

Year of construction

95->

Code

WIRE COLOUR / POSITION

Turn signal left

brown

Turn signal right

orange

Turn signal position

At the turn signal switch, in the wires left to the rear or also directly at the tail lamps.

Car lock type

Type3

Car lock open

brown

Car lock close

orange

Car lock position

Wiring harness coming from driver's door.

Renault

Model

Rapid

Year of construction

93->

Code

WIRE COLOUR / POSITION

Turn signal left

purple

Turn signal right

purple

Turn signal position

At the turn signal switch, in the wires left to the rear or also directly at the tail lamps.

Car lock type

Type3

Car lock open

white-purple

Car lock close

white-red

Car lock position

Wiring harness coming from driver's door.

Renault

Model

Safrane

Year of construction

94->

Code

WIRE COLOUR / POSITION

Turn signal left

purple-white

Turn signal right

orange-red

Turn signal position

At the turn signal switch, in the wires left to the rear or also directly at the tail lamps.

Car lock type

Type3

Car lock open

white-orange

Car lock close

white-green

Car lock position

Wiring harness coming from driver's door.

Renault

Model

Safrane

Year of construction

95->

Code

WIRE COLOUR / POSITION

Turn signal left

pink

Turn signal right

purple-grey

Turn signal position

At the turn signal switch, in the wires left to the rear or also directly at the tail lamps.

Car lock type

Type3

Car lock open

green-grey-black

Car lock close

green-grey-orange

Car lock position

Wiring harness coming from driver's door.

Renault

Model

Safrane

Year of construction

96->

Code

WIRE COLOUR / POSITION

Turn signal left

pink-red

Turn signal right

pink-white

Turn signal position

At the turn signal switch, in the wires left to the rear or also directly at the tail lamps.

Car lock type

Type2

Car lock open

green A2

Car lock close

green A3

Car lock position

Wiring harness coming from driver's door.

Renault

Model

Scenic

Year of construction

96->

Code

WIRE COLOUR / POSITION

Turn signal left

brown

Turn signal right

brown

Turn signal position

At the turn signal switch, in the wires left to the rear or also directly at the tail lamps.

Car lock type

Type2

Car lock open

pink

Car lock close

purple

Car lock position

Wiring harness coming from driver's door.

Renault

Model	Year of construction	Code
Twingo	97->	E36

WIRE COLOUR / POSITION

Turn signal left	purple B6
Turn signal right	beige B7
Turn signal position	At the turn signal switch, in the wires left to the rear or also directly at the tail lamps.
Car lock type	Type4
Car lock open	green-grey
Car lock close	purple-grey
Car lock position	Wiring harness coming from driver's door.

Renault

Model	Year of construction	Code
Twingo	2000->	

WIRE COLOUR / POSITION

Turn signal left	brown
Turn signal right	purple
Turn signal position	At the turn signal switch, in the wires left to the rear or also directly at the tail lamps.
Car lock type	Type2
Car lock open	grey
Car lock close	grey
Car lock position	18-pin plug (blue) in fuse box (left).