

RCA 300

Car Alarm &
Radio Remote Control
with turn signal triggering



Mounting Instructions

Seat

■ Warranty

No responsibility is taken for the correctness of the information contained herein. No liability is assumed for errors or misprints.

Due to the high quality of our product, we grant you a 2-year warranty. The function and durability of the central lock control unit depends to a large degree on appropriate mounting. Understandably, we cannot grant any warranty for defects ascribable to wrong or erroneous mounting. In particular, these include charred or burnt components.

Reconsignment of seemingly defective components is categorically at the customer's expense. Trouble shooting is only possible provided that a description of the defect and a copy of the invoice are enclosed. Please note that handling or connecting errors are outside the scope of this warranty. Understandably, we cannot assume liability for defects thus caused.

We grant a 2-year warranty from date of purchase on all components. Warranty includes free of charge trouble shooting of those defects verifiably ascribable to the use of faulty material or to manufacturing errors. All other claims are exempt from liability.

No responsibility or liability is taken for damages or consequential loss relating to this product. Repairation, amendments, supply of spare parts and refunding of purchase price are reserved.

Warranty expires if:

- 1) the device has been altered or if attempts at repairing the device have been made.
- 2) the device has been surcharged.
- 3) damages have come about due to the ignoring of mounting instructions.
- 4) the device has been connected to inadequate current or voltage.
- 5) the appropriate polarity of the device has not been observed.
- 6) the device has been damaged due to maloperation.
- 7) the device has been damaged due to negligent handling.
- 8) the device has been damaged due to by-passed or wrong fuses.

Key alteration:

The blank keys that are screwed into the handheld transmitters only serve as samples (models). You have to have your own car key modified according to this model and screw it onto the transmitter. You may decide for yourself whether you want to use your original car key or have a copy cut in order to have it modified.

Immobilizer:

The immobilizer transponder chip has to be stuck into the handheld transmitter (above the LED).

Receiver



■ Type 1

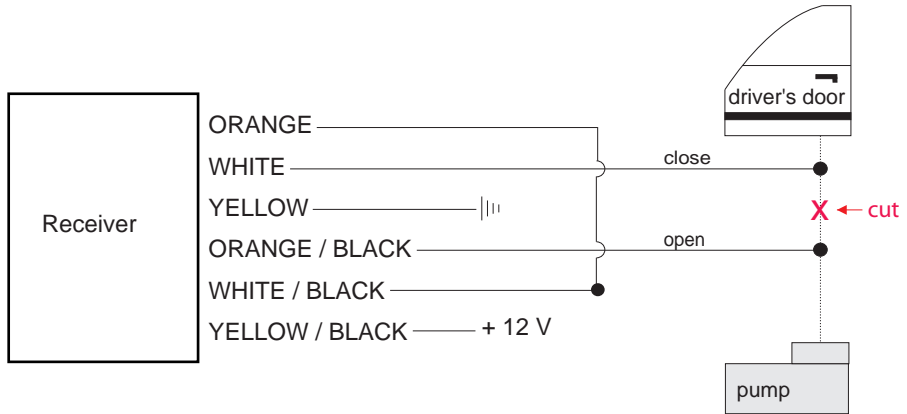

||| GROUND

■ Type 2

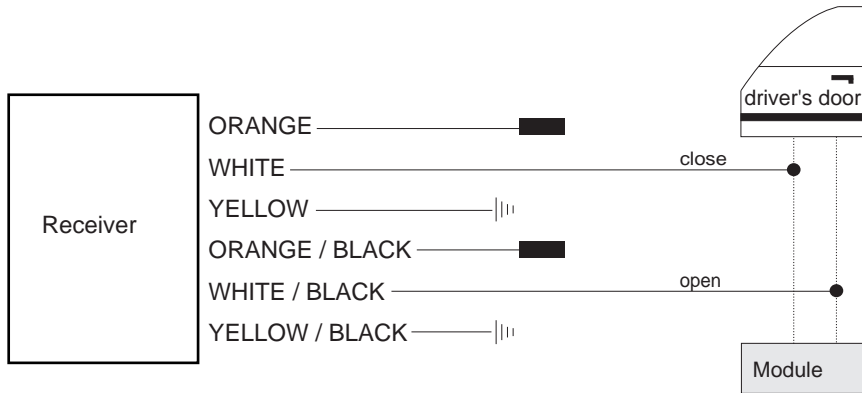

||| GROUND

■ not required, please insulate

■ Type 3



[] not required, please insulate

■ Type 4



■ Type 5: (Pin)



■ not required, please insulate

■ Type 6: (with resistance)



||| GROUND

■ not required, please insulate

■ Type 7



||| GROUND

■ not required, please insulate

■ Type 8: (actuator)



||| GROUND

Seat

Model

Arosa

Year of construction

97->

Code

6H

WIRE COLOUR / POSITION

Turn signal left

black-white

Turn signal right

black-green

Turn signal position

At the turn signal switch, in the wires left to the rear or also directly at the tail lamps.

Car lock type

Type2

Car lock open

blue-purple

Car lock close

grey-yellow

Car lock position

Wiring harness coming from driver's door.

Seat

Model	Year of construction	Code
Cordoba	96->	-

WIRE COLOUR / POSITION

Turn signal left	white-black
Turn signal right	green-black
Turn signal position	At the turn signal switch, in the wires left to the rear or also directly at the tail lamps.
Car lock type	Type3
Car lock open	red-blue
Car lock close	red-green
Car lock position	Wiring harness coming from driver's door.

Seat

Model	Year of construction	Code
Ibiza	98->	-

WIRE COLOUR / POSITION

Turn signal left	black-white
Turn signal right	black-green
Turn signal position	At the turn signal switch, in the wires left to the rear or also directly at the tail lamps.
Car lock type	Type3
Car lock open	red-green
Car lock close	red-blue
Car lock position	Wiring harness coming from driver's door.

Seat

Model	Year of construction	Code
Ibiza GLX	96->	-

WIRE COLOUR / POSITION

Turn signal left	black-white
Turn signal right	white-purple
Turn signal position	At the turn signal switch, in the wires left to the rear or also directly at the tail lamps.
Car lock type	Type3
Car lock open	white-red
Car lock close	grey-blue
Car lock position	Wiring harness coming from driver's door.

Seat

Model

Leon

Year of construction

2002->

Code

-

WIRE COLOUR / POSITION

Turn signal left

black-green

Turn signal right

black-white

Turn signal position

At the turn signal switch, in the wires left to the rear or also directly at the tail lamps.

Car lock type

Type2

Car lock open

yellow-green / pin 4

Car lock close

yellow-blue / pin 24

Car lock position

29-pin plug (directly in the driver's door).

Seat

Model

Toledo

Year of construction

91->

Code

1L

WIRE COLOUR / POSITION

Turn signal left

black-white

Turn signal right

black-green

Turn signal position

At the turn signal switch, in the wires left to the rear or also directly at the tail lamps.

Car lock type

Type3

Car lock open

red-blue

Car lock close

red-green

Car lock position

Wiring harness coming from driver's door.

Seat

Model

Toledo

Year of construction

96->

Code

-

WIRE COLOUR / POSITION

Turn signal left

white-black

Turn signal right

green-black

Turn signal position

At the turn signal switch, in the wires left to the rear or also directly at the tail lamps.

Car lock type

Type3

Car lock open

brau-black

Car lock close

green-black

Car lock position

Wiring harness coming from driver's door.