

RCA 301

Car Alarm &
Radio Remote Control
with turn signal triggering



Mounting Instructions

Volvo

■ Warranty

No responsibility is taken for the correctness of the information contained herein. No liability is assumed for errors or misprints.

Due to the high quality of our product, we grant you a 2-year warranty. The function and durability of the central lock control unit depends to a large degree on appropriate mounting. Understandably, we cannot grant any warranty for defects ascribable to wrong or erroneous mounting. In particular, these include charred or burnt components.

Reconsignment of seemingly defective components is categorically at the customer's expense. Trouble shooting is only possible provided that a description of the defect and a copy of the invoice are enclosed. Please note that handling or connecting errors are outside the scope of this warranty. Understandably, we cannot assume liability for defects thus caused.

We grant a 2-year warranty from date of purchase on all components. Warranty includes free of charge trouble shooting of those defects verifiably ascribable to the use of faulty material or to manufacturing errors. All other claims are exempt from liability.

No responsibility or liability is taken for damages or consequential loss relating to this product. Repairation, amendments, supply of spare parts and refunding of purchase price are reserved.

Warranty expires if:

- 1) the device has been altered or if attempts at repairing the device have been made.
- 2) the device has been surcharged.
- 3) damages have come about due to the ignoring of mounting instructions.
- 4) the device has been connected to inadequate current or voltage.
- 5) the appropriate polarity of the device has not been observed.
- 6) the device has been damaged due to maloperation.
- 7) the device has been damaged due to negligent handling.
- 8) the device has been damaged due to by-passed or wrong fuses.

Key alteration:

The blank keys that are screwed into the handheld transmitters only serve as samples (models). You have to have your own car key modified according to this model and screw it onto the transmitter. You may decide for yourself whether you want to use your original car key or have a copy cut in order to have it modified.

Immobilizer:

The immobilizer transponder chip has to be stuck into the handheld transmitter (above the LED).

Receiver

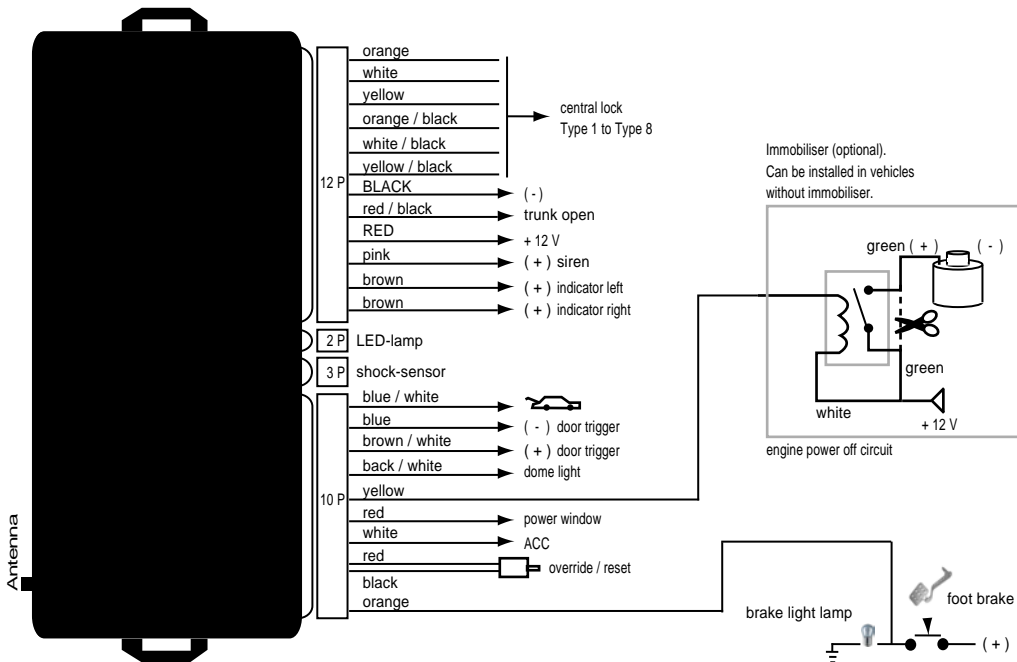

■ Type 1

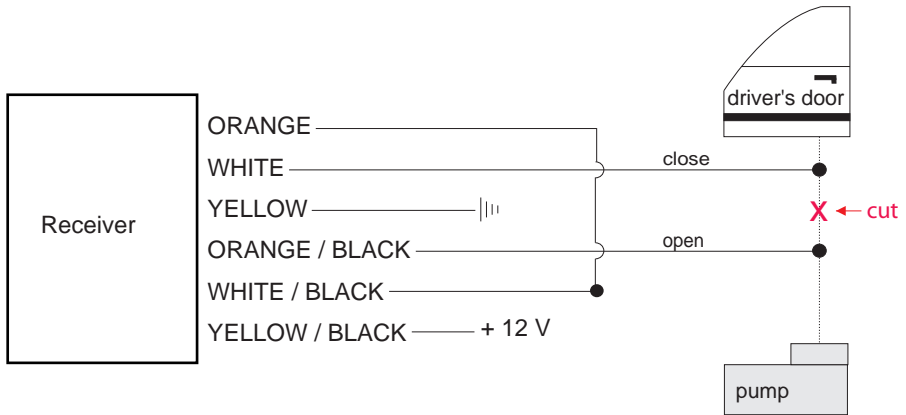

| ||| GROUND

■ Type 2



||| GROUND

■ not required, please insulate

■ Type 3



[] not required, please insulate

■ Type 4



■ Type 5: (Pin)

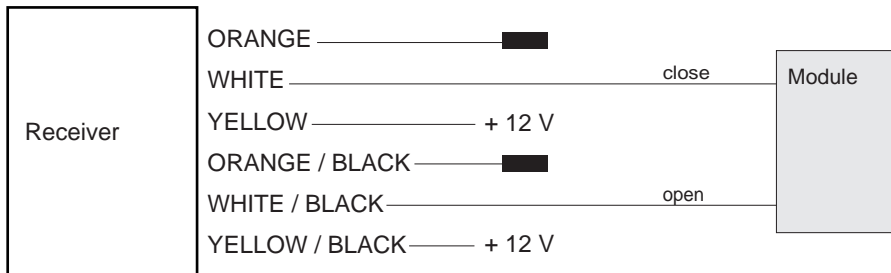

■ not required, please insulate

■ Type 6: (with resistance)



||| GROUND

■ not required, please insulate

■ Type 7



[ground symbol] GROUND

[black square] not required, please insulate

■ Type 8: (actuator)



| | | GROUND

Volvo

Model

850

Year of construction

93->

Code

-

WIRE COLOUR / POSITION

Turn signal left

green

Turn signal right

blue-green

Turn signal position

At the turn signal switch, in the wires left to the rear or also directly at the tail lamps.

Car lock type

Type2

Car lock open

yellow-brown or yellow-red

Car lock close

yellow or yellow-grey

Car lock position

Wiring harness coming from driver's door.

Volvo

Model

940/960

Year of construction

96->

Code

-

WIRE COLOUR / POSITION

Turn signal left

green

Turn signal right

green-blue

Turn signal position

At the turn signal switch, in the wires left to the rear or also directly at the tail lamps.

Car lock type

Type2

Car lock open

green-black

Car lock close

yellow-black

Car lock position

Wiring harness coming from driver's door.

Volvo

Model

S40/V40

Year of construction

97->

Code

-

WIRE COLOUR / POSITION

Turn signal left

blue-white or blue-black

Turn signal right

brown-yellow or brown-black

Turn signal position

At the turn signal switch, in the wires left to the rear or also directly at the tail lamps.

Car lock type

Type3

Car lock open

grey

Car lock close

grey-green

Car lock position

Wiring harness coming from driver's door.

Volvo

Model

S70/V70

Year of construction

97->

Code

-

WIRE COLOUR / POSITION

Turn signal left

blue-green

Turn signal right

green-blue

Turn signal position

At the turn signal switch, in the wires left to the rear or also directly at the tail lamps.

Car lock type

Type2

Car lock open

red-grey

Car lock close

yellow-grey

Car lock position

Wiring harness coming from driver's door.